

Introduction

Thanks for choosing I-DC48V integrated wall mounted energy storage system (ESS). This user manual introduces the product information, using guidance, safety precautions and maintenance of the system. To ensure personal and property safety or use this product efficiently, please take your time to read and familiarize yourself with the contents of this user manual as it contains important information about the operation, servicing, troubleshooting and limitations of the system.

Note: Retain this document in a safe and accessible location for future reference. The manufacturer shall not be legally responsible for any equipment damage or personnel injury caused by incorrect installation or operation other than that is covered in this manual.

Disclaimer

The information included in this manual is accurate at the time of publication. However, as the improvement of technology, this manual is subject to change without prior notice. In addition, the illustrations in this manual are meant only to help explain system configuration concepts and installation instructions.



US:
405 Boulder Court
Pleasanton, CA 94566
(925) 398-8466, (925) 954-4770
team@innoliaenergy.com



India:
16-11-741/c/3 Moosarambagh
Dilsukhnagar, Hyderabad 500060
040-40274296, +91-7799992037
+91-9010752755, info@innoliaenergy.com



Factory:
284-2-88/1 Lingotam
Kuntlagudem, Telangana 508252
+91-9182543576, +91-9825969807
+91-9866586771, sales@innoliaenergy.com



Product Overview

This chapter introduces the functions, working principles and Structural features of the I-DC48V energy storage system.

Brief introduction

The integrated energy storage system is a combination of inverter and battery, which is mainly used in household energy storage system as picture F2-2.

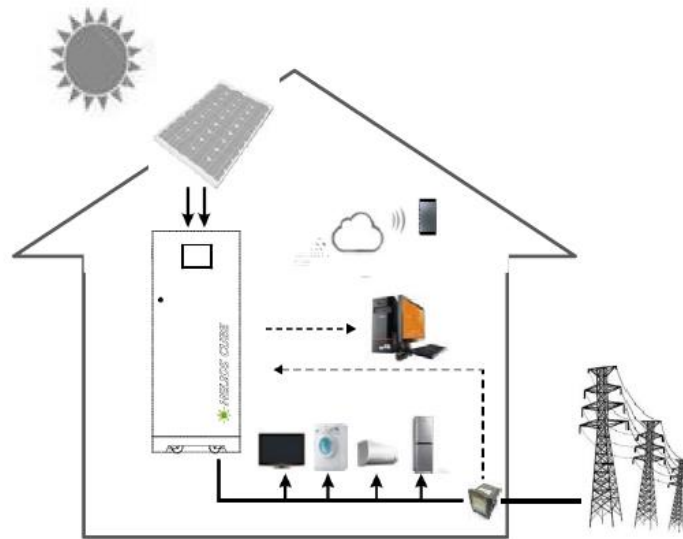

F2-2 Energy Storage System

The combination of a PV, battery power grid, and electricity meter forms a household storage system. With this system, your family could achieve energy independent. Take your energy future into your own hands and reduce your energy costs to a minimum. The ESS system can also be used as Emergency power supply.





INNOLIA ENERGY

INTEGRATED SOLAR, LITHIUM-BATTERY & EV COMPANY

Residential Storage



Fig: product image



US:
405 Boulder Court
Pleasanton, CA 94566
(925) 398-8466, (925) 954-4770
team@innoliaenergy.com



India:
16-11-741/c/3 Moosarambagh
Dilsukhnagar, Hyderabad 500060
040-40274296, +91-7799992037
+91-9010752755, info@innoliaenergy.com



Factory:
284-2-88/1 Lingotam
Kuntlagudem, Telangana 508252
+91-9182543576, +91-9825969807
+91-9866586771, sales@innoliaenergy.com



Inverter Technical Specification

Model	I-DC48V
PV Input Characteristics	
MPPT	2 (parallelable)
Max. DC Volt (VDC)	900V
Full load MPPT range (VDC)	250 ~850V
Max. DC current (ADC)	10/10A
Starting voltage (VDC)	250V
AC Output Characteristic	
Rated Output Power (W)	5000W
Max. Output Power (W)	5000W
Max. Output Current (Aac)	21A
Rated output Voltage (VAC)	220/230/240Va.c. ; 50/60Hz
Input Voltage Range (VAC)	187 ~ 264Va.c. ; 47.5~52.5Hz/57.5~62.5Hz
Power factor	>0.99
Total Harmonic Current Distortion	<3%
Grid Type	Single phase
Categories of AC terminal over voltage	Category III
Off grid output (VAC)	220/230/240Va.c. ; 50/60Hz ; THDu<3% (Linear load)
On/off grid switching time(ms)	10ms
Grid tie inverter efficiency (%)	97%
Grid tie efficiency for EU (%)	96.2%
MPPT efficiency (%)	99.9%
Off grid inverter efficiency (%)	94%
Island protection time (s)	2s
Protection characteristics	
Residual current protection	Integrated
Island protection	Integrated
Output over current protection	Integrated



US:
405 Boulder Court
Pleasanton, CA 94566
(925) 398-8466, (925) 954-4770
team@innoliaenergy.com



India:
16-11-741/c/3 Moosarambagh
Dilsukhnagar, Hyderabad 500060
040-40274296, +91-7799992037
+91-9010752755, info@innoliaenergy.com



Factory:
284-2-88/1 Lingotam
Kuntlagudem, Telangana 508252
+91-9182543576, +91-9825969807
+91-9866586771, sales@innoliaenergy.com

**INNOLIA ENERGY**

INTEGRATED SOLAR, LITHIUM-BATTERY & EV COMPANY

Residential Storage

Insulation impedance protection	Integrated
General parameters	
Environment type	Outdoor or indoor
Installation mode	Wall mount
Protection level	IP20
Topology	Non-transform
Operation temperature range (°C)	0~45 (>40°C Reduce load)
Heat dissipation mode	Forced air cooling
Noise index (dB)	50 (foreward1m)
Altitude (m)	2000m
RH (%)	0 ~95%
Display	Touch screen
Dimension(W×H×D) (mm)	1070×735×240mm
Weight(kg)	125kg

Battery Technical specification

Parameters	51.2V 105AH	51.2V 210AH	51.2V 315AH
Energy	5376Wh	10752Wh	16128Wh
Chemistry	LiFePO4		
Nominal Voltage	51.2V		
Rated Capacity	105AH	210AH	315AH
Charging Voltage	58.4V		
End Voltage	44.8V		
Max. Continuous Charging Current	50A		
Max. Continuous Discharge Current	80A		
Temperature °C	Charge: 0~45°C		
	Discharge: -20~60°C		
Life Cycles(at 80% DOD)	80%		
Weight	125Kg	165Kg	200Kg



US:
405 Boulder Court
Pleasanton, CA 94566
(925) 398-8466, (925) 954-4770
team@innoliaenergy.com



India:
16-11-741/c/3 Moosarambagh
Dilsukhnagar, Hyderabad 500060
040-40274296, +91-7799992037
+91-9010752755, info@innoliaenergy.com



Factory:
284-2-88/1 Lingotam
Kuntlagudem, Telangana 508252
+91-9182543576, +91-9825969807
+91-9866586771, sales@innoliaenergy.com



Dimensions of Cabinet (LxWxH)	1070*735*240mm	1350*735*240mm	1660*735*240mm
Warranty	5years		
Protection	BMS Protection (Short Circuit Protection, Over voltage Protection, Under Voltage Protection, Over Discharge/ Charge Protection/ Temperature)		
Communication	Modbus		

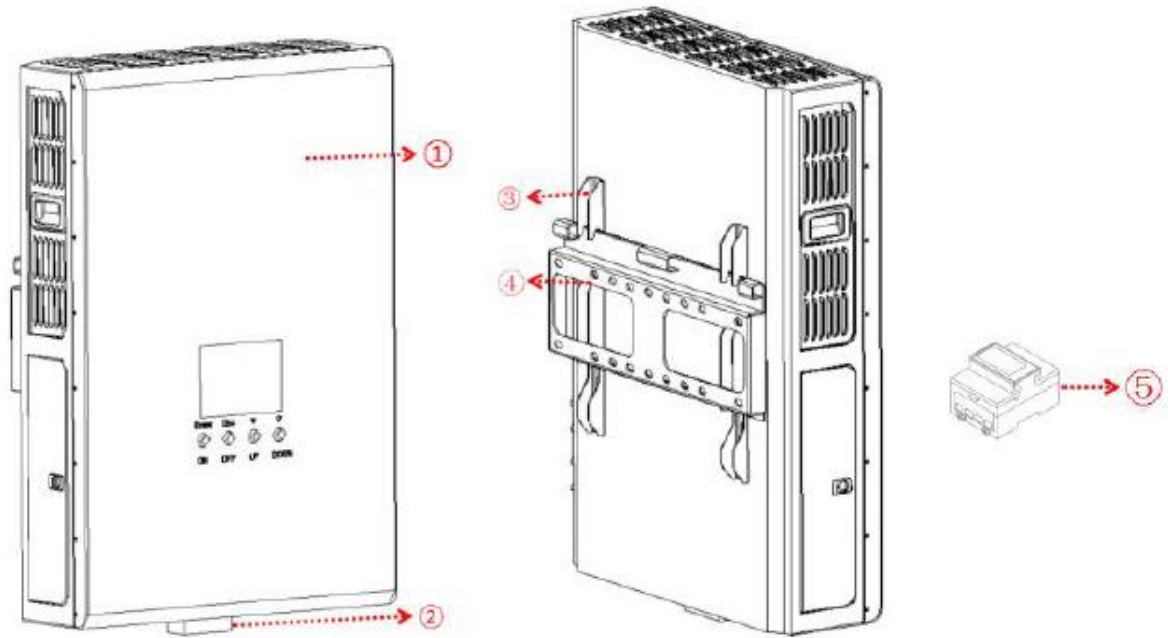

F2-4

Items	Description
①	The battery system
②	WiFi Module
③	Mounting hook
④	Mounting Bracket
⑤	Electricity meter





Introduction of Ports and Interface

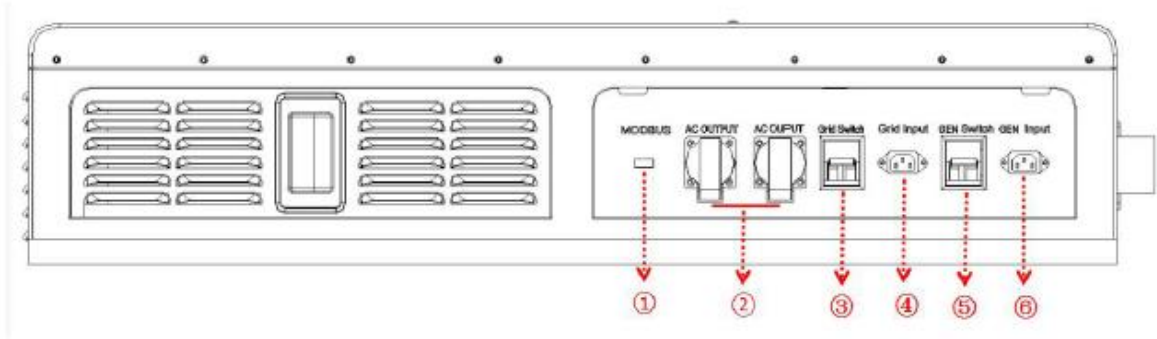

T2-5 Port 1

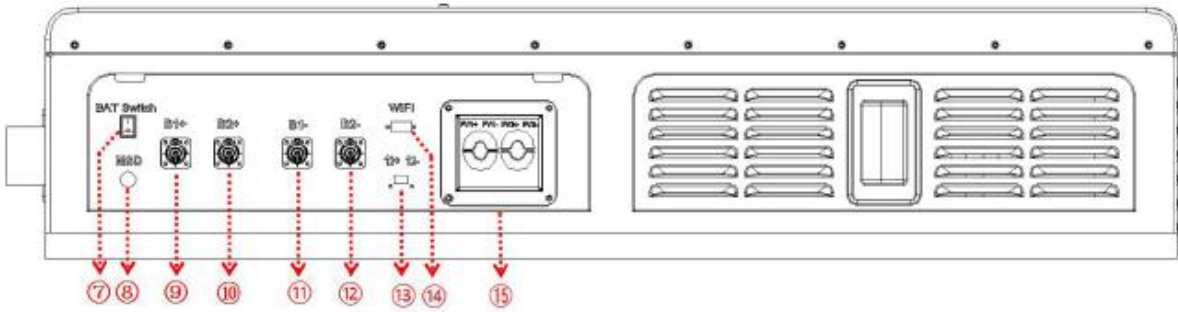

T2-6 Port 2

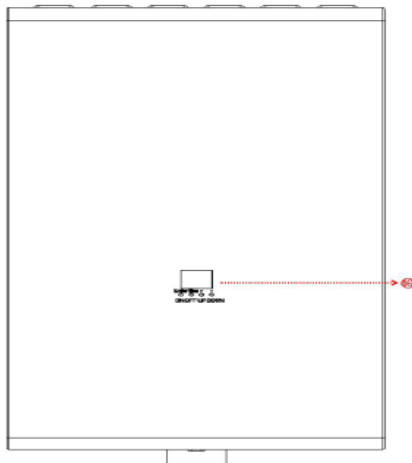

T2-7 LCD Screen





INNOLIA ENERGY

INTEGRATED SOLAR, LITHIUM-BATTERY & EV COMPANY

Residential Storage

1. MODBUS: Smart meter communication interface
2. AC OUTPUT: AC INPUT PORT
3. GRID SWITCH
4. GRID INPUT PORT
5. GENERATOR INPUT SWITCH
6. GENERATOR INPUT PORT
7. BATTERY SWITCH
8. MSD: BATTERY MAINTANCE SWITCH
9. B1+: BATTERY 1 POSITIVE
10. B2+: BATTERY 2 POSITIVE
11. B1-: BATTERY 1 NEGITIVE
12. B2-: BATTERY 2 NEGITIVE
13. 12V Port: 12V POWER SUPPLY OUTPUT PORT (SUPPLY TO WIFI MODULE)
14. WIFI: WIFI MODULE CONNECTION PORT
15. PV INPUT PORT
16. LCD DISPLAY



US:
405 Boulder Court
Pleasanton, CA 94566
(925) 398-8466, (925) 954-4770
team@innoliaenergy.com



India:
16-11-741/c/3 Moosarambagh
Dilsukhnagar, Hyderabad 500060
040-40274296, +91-7799992037
+91-9010752755, info@innoliaenergy.com



Factory:
284-2-88/1 Lingotam
Kuntlagudem, Telangana 508252
+91-9182543576, +91-9825969807
+91-9866586771, sales@innoliaenergy.com



Working Principle

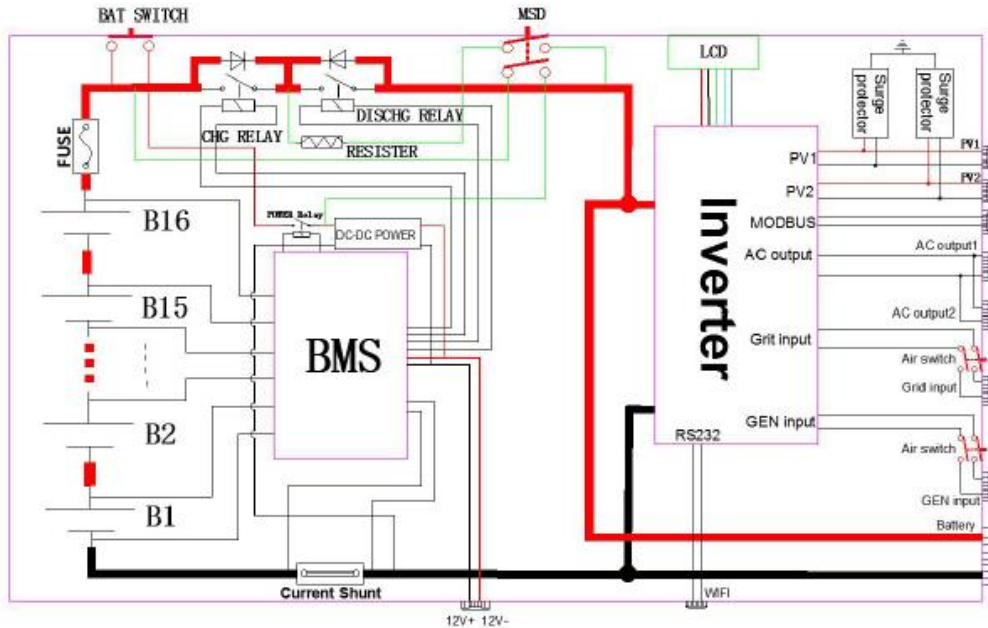

T2-8 schematic diagram

To prevent the load leakage affecting the inverter, it is recommended to connect an isolation transformer outside the load output port. Isolation transformer secondary N line connected to PE.

Working Mode

According to the power grid conditions, the working state of the system can be switched automatically. There are four working modes: Storage mode, Load mode, peak cutting and valley filling mode, and off grid emergency mode.

Storage Mode



US:
405 Boulder Court
Pleasanton, CA 94566
(925) 398-8466, (925) 954-4770
team@innoliaenergy.com



India:
16-11-741/c/3 Moosarambagh
Dilsukhnagar, Hyderabad 500060
040-40274296, +91-7799992037
+91-9010752755, info@innoliaenergy.com



Factory:
284-2-88/1 Lingotam
Kuntlagudem, Telangana 508252
+91-9182543576, +91-9825969807
+91-9866586771, sales@innoliaenergy.com



INNOLIA ENERGY

INTEGRATED SOLAR, LITHIUM-BATTERY & EV COMPANY

Residential Storage

At the storage mode, the system will charge the battery prior until it is fully charged. And the stored energy can be used for emergency application. As shown in T2-9.

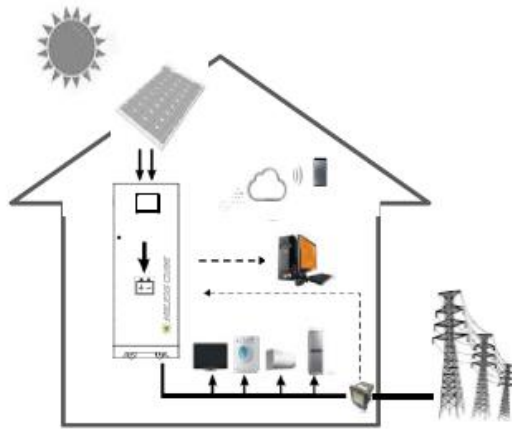

Load Mode

Under load mode, the system will ensure the power of consumption load first to reduce the power taken from public power grid. As shown in T2-10.

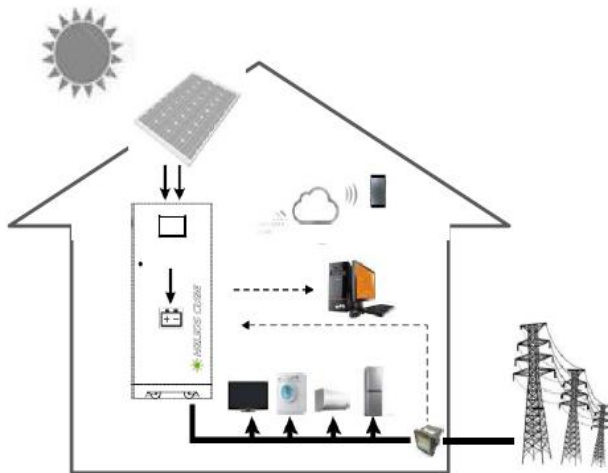

US:
405 Boulder Court
Pleasanton, CA 94566
(925) 398-8466, (925) 954-4770
team@innoliaenergy.com



India:
16-11-741/c/3 Moosarambagh
Dilsukhnagar, Hyderabad 500060
040-40274296, +91-7799992037
+91-9010752755, info@innoliaenergy.com



Factory:
284-2-88/1 Lingotam
Kuntlagudem, Telangana 508252
+91-9182543576, +91-9825969807
+91-9866586771, sales@innoliaenergy.com



INNOLIA ENERGY

INTEGRATED SOLAR, LITHIUM-BATTERY & EV COMPANY

Residential Storage

Peak Cutting and Valley Filling

The customer can freely set the charge and discharge time of the battery through the upper host PC of the inverter. Set the system to load mode in peak hours. And switch to storage mode at the low price period. In this way, the difference of electricity price in peak and valley period can be reasonably utilized to bring benefits to your family. As shown in the following picture.

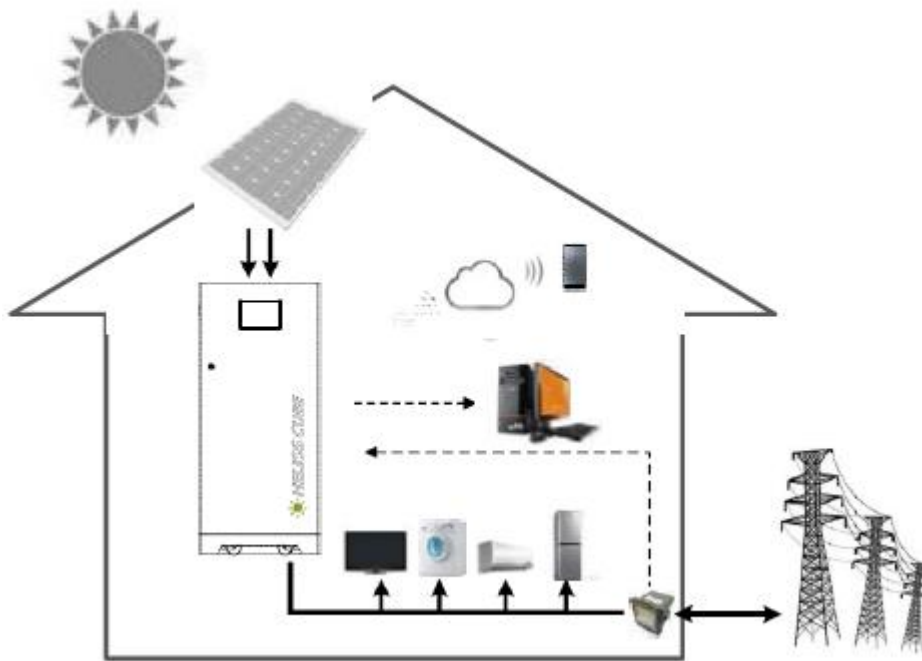

US:
405 Boulder Court
Pleasanton, CA 94566
(925) 398-8466, (925) 954-4770
team@innoliaenergy.com



India:
16-11-741/c/3 Moosarambagh
Dilsukhnagar, Hyderabad 500060
040-40274296, +91-7799992037
+91-9010752755, info@innoliaenergy.com



Factory:
284-2-88/1 Lingotam
Kuntlagudem, Telangana 508252
+91-9182543576, +91-9825969807
+91-9866586771, sales@innoliaenergy.com



Off Grid Emergency

When the public power grid is cut off, the system can be used as a backup power supply. As shown in T2-12.

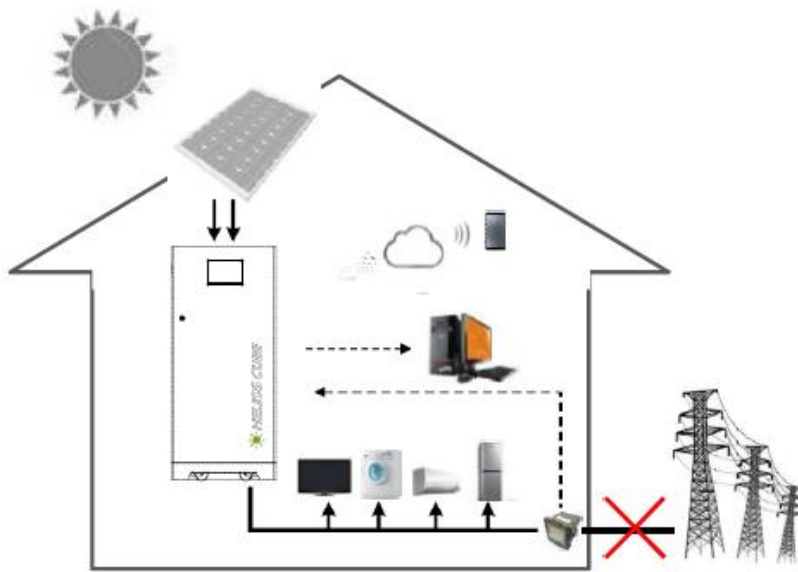

Power On/Off

The ESS system needs to be disconnected during transportation or storage. During the installation, debugging and use of the product, it is required to follow the operation sequence of power on and power off and operate safely.



Boot Up

First plug in grid input port for power supply, and then turn on grid switch, after the inverter is fully started, close the maintenance switch (MSD), then close the battery switch (BAT switch) after 2 seconds, then disconnect the maintenance switch (MSD) after 5 seconds, the normal start of the equipment completed.

Shut Down

Disconnect the output, external load stop to work, and then unplug the connection from the AC output / grid port, then open the grid switch and Gen switch, and disconnect the 24 input connections. Unplug from the gen / PV / Gen port. Then disconnect the bat switch. And then disconnect Battery connection. Finally, unplug the Wi-Fi module and smart meter.



US:
405 Boulder Court
Pleasanton, CA 94566
(925) 398-8466, (925) 954-4770
team@innoliaenergy.com



India:
16-11-741/c/3 Moosarambagh
Dilsukhnagar, Hyderabad 500060
040-40274296, +91-7799992037
+91-9010752755, info@innoliaenergy.com



Factory:
284-2-88/1 Lingotam
Kuntlagudem, Telangana 508252
+91-9182543576, +91-9825969807
+91-9866586771, sales@innoliaenergy.com

Installation and Commissioning

This chapter introduces the installation of integrated ESS, including unpacking, inspection, installation preparation, installation process, mechanical installation, cable connection, system inspection and commissioning, etc.

3.1 Installation Process

The installation process of the ESS system is shown in T3-1.

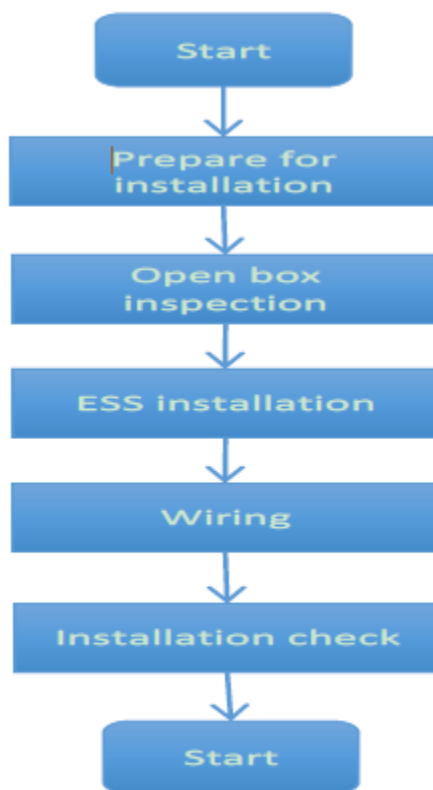

T3-1 Installation Process













INNOLIA ENERGY

INTEGRATED SOLAR, LITHIUM-BATTERY & EV COMPANY

Residential Storage

Tools

Name	Pictures	Purpose
Current meter		Current measurement
Multi-Meter		Electronics parameter
Label		Marking
Screwdriver		Fix or dismantle
Socket wrench		Fix or dismantle
Adjustable wrench		Fix or dismantle
Torque wrench		Fix or dismantle
Crimping pliers		Suppress terminals
Bevel pliers		Cutting
Wire stripper		Stripping



US:
 405 Boulder Court
 Pleasanton, CA 94566
 (925) 398-8466, (925) 954-4770
 team@innoliaenergy.com



India:
 16-11-741/c/3 Moosarambagh
 Dilsukhnagar, Hyderabad 500060
 040-40274296, +91-7799992037
 +91-9010752755, info@innoliaenergy.com



Factory:
 284-2-88/1 Lingotam
 Kuntlagudem, Telangana 508252
 +91-9182543576, +91-9825969807
 +91-9866586771, sales@innoliaenergy.com



INNOLIA ENERGY

INTEGRATED SOLAR, LITHIUM-BATTERY & EV COMPANY

Residential Storage

Claw hammer		For knocking, installing and
Percussion drill		drill hole
Insulating tape		Electrical insulation
Cotton		For cleaning panel and shell
Brush		For cleaning panel and shell
Heat shrinkable sleeve (Φ50, Φ70)		Electrical insulation
Hot air gun		For blowing heat shrink sleeve
Electric knife		Stripping
Labor protection		Hands protection
Anti-static gloves		ESD protection
Insulating gloves		Electric shock protection
Tie band		Tie of wire
Hydraulic clamp		Pressing OT terminal



US:
405 Boulder Court
Pleasanton, CA 94566
(925) 398-8466, (925) 954-4770
team@innoliaenergy.com



India:
16-11-741/c/3 Moosarambagh
Dilsukhnagar, Hyderabad 500060
040-40274296, +91-7799992037
+91-9010752755, info@innoliaenergy.com



Factory:
284-2-88/1 Lingotam
Kuntlagudem, Telangana 508252
+91-9182543576, +91-9825969807
+91-9866586771, sales@innoliaenergy.com

Installation Locations

The operating environment has certain influence on the service life and performance of the equipment. Therefore, please use the device at the required locations.

Required

There must be no inflammable or explosive materials nearby. The ambient temperature should be within the range of $-10 \sim 45^{\circ}\text{C}$. Battery pack must be installed on walls that are upright and can support battery weight.

Recommended

- The building should be designed to withstand earthquakes.
- The waterproof and properly ventilated area is recommended.
- (IP20) Install this product out of reach of children and animals.
- Do not expose the system directly to the sunshine.
- Do not install the ESS system in the working environment with metal conductive dust.



US:
405 Boulder Court
Pleasanton, CA 94566
(925) 398-8466, (925) 954-4770
team@innoliaenergy.com



India:
16-11-741/c/3 Moosarambagh
Dilsukhnagar, Hyderabad 500060
040-40274296, +91-7799992037
+91-9010752755, info@innoliaenergy.com



Factory:
284-2-88/1 Lingotam
Kuntlagudem, Telangana 508252
+91-9182543576, +91-9825969807
+91-9866586771, sales@innoliaenergy.com



Clearance

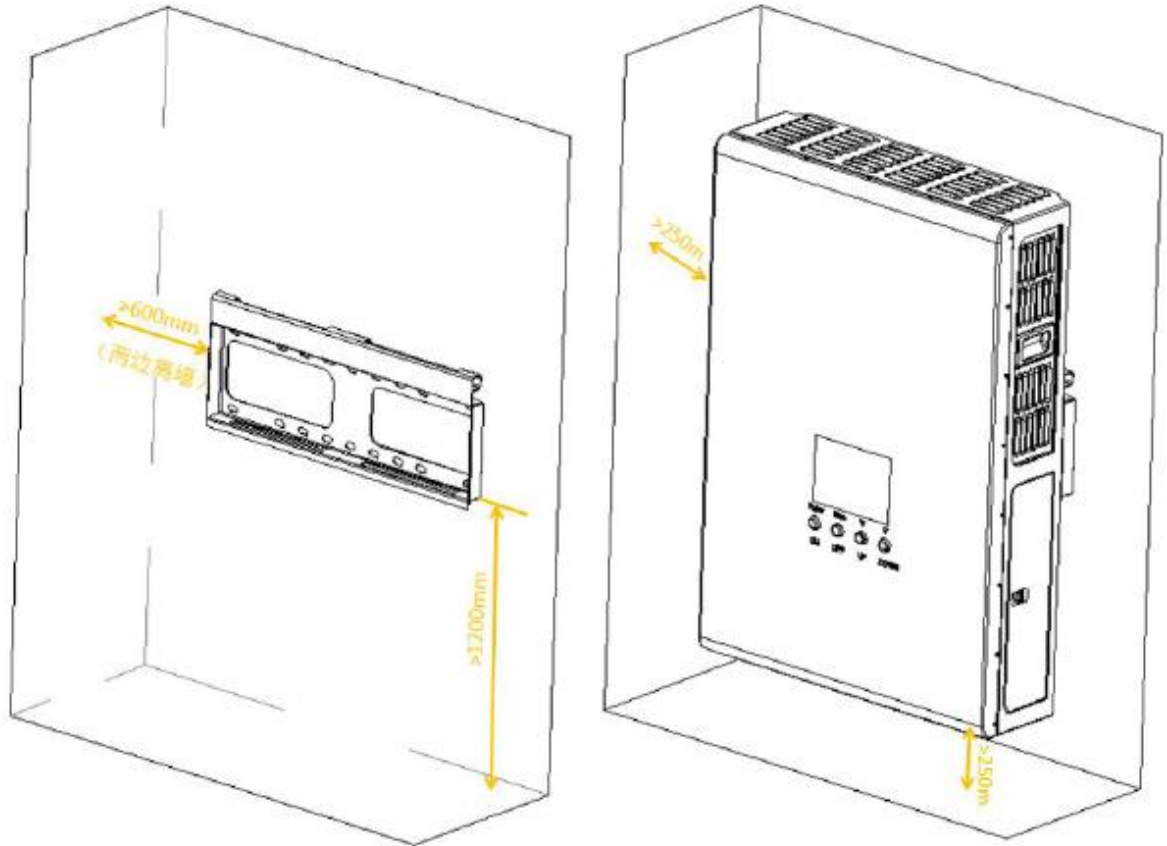

T3-2 Recommended clearances(mm)

Recommended clearance as shown in the picture, To the left, right, top and bottom for proper ventilation and convenience of the installer. Do not cover the ventilation holes on the left and right sides of the system.

I / O Cable

For the photovoltaic module input and load and grid power output cable, please refer to T3-2 for recommended current and diameter.





T3-2 cable diameter (mm²)

PV	+	12	6
	-	12	6

Electrical Connection

- When connecting the input or output cable the corresponding plug shall meet the power requirements. Each plug or socket should be allowed to flow 16A current.
- Do not reverse polarity.
- Disconnect battery from power and load, then power off battery before installation and maintenance.
- Make sure the system is properly connected to the ground.
- The electrical connection of the system (with solar inverter) is shown in T3-14 :

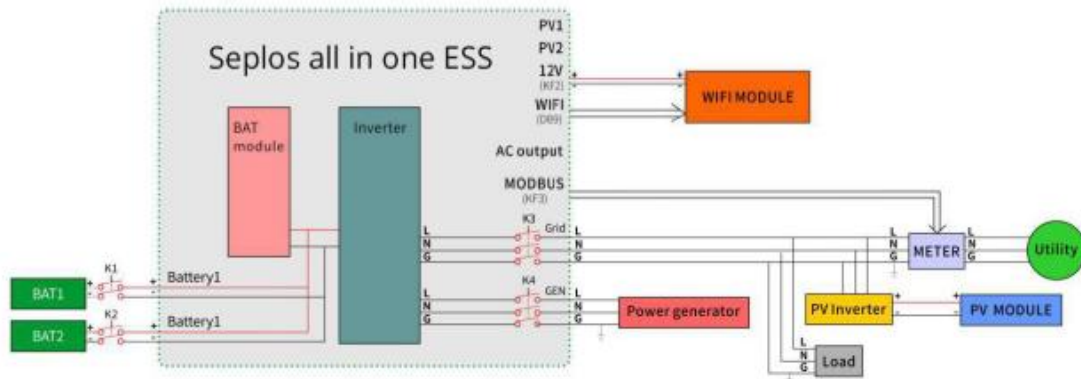

T3-14 Wiring diagram(with solar inverter)





The electrical connection of the system (without solar inverter) is shown in T3-15:

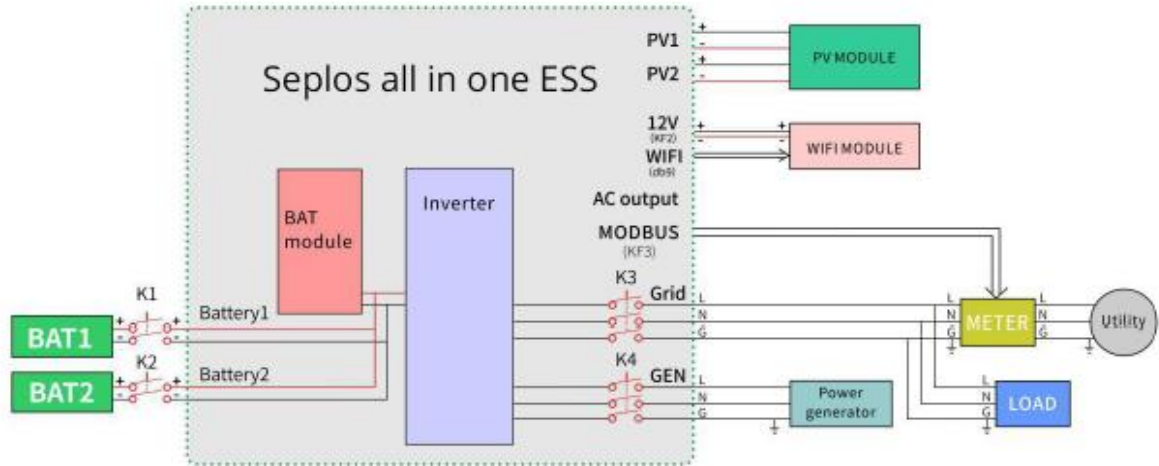

T3-15 Wiring diagram(without solar inverter)

The bypass switch can be added selectively, mainly used for inverter maintenance, but must be disconnected when using the integrated ESS.

In order to prevent important load leakage from affecting the inverter, it is recommended to connect an isolation transformer outside the load output port; the secondary N line of the isolation transformer is connected with PE.

Step 1 PV module connection

- Connect the input wiring of PV module into PV port (15)



Step 2 Wiring connect to grid

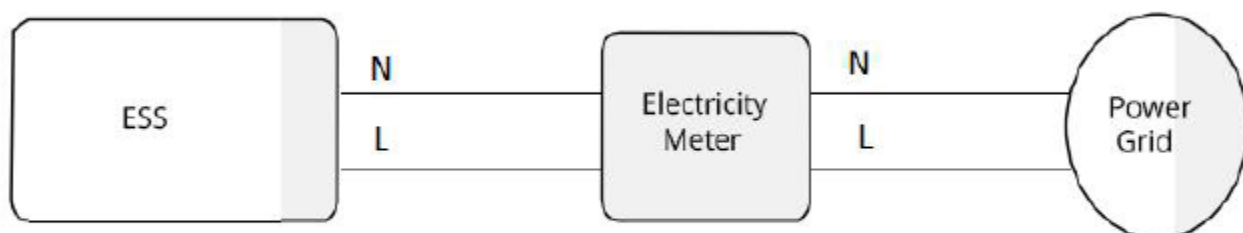

T 3-16 Electricity meter connection

- Plug in the GRID INPUT connector
- Connect the electricity meter between Grid power and ESS system, as shown in Figure 3-16.

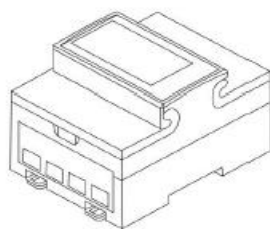

T3-17 Electricity Meter

Step 3 Wiring connect to load

- Insert the plug into the AC OUTPUT port
- The specification of selected plug shall meet the load power requirement.



Step 4 parallel wire connections (Option)

- Disconnect the output switch of the battery module before the parallel battery module is connected.
- Close the battery switch after parallel battery module connected.
- Batteries of the same capacity, type and manufacturer must be used, and the voltage difference of parallel battery pack is within 3V.

Step 5 Installation of WIFI module

- WIFI module is fixed at the bottom of ESS.
- Install the WIFI module after completing the installation of ESS.
- As shown in figure 3-18

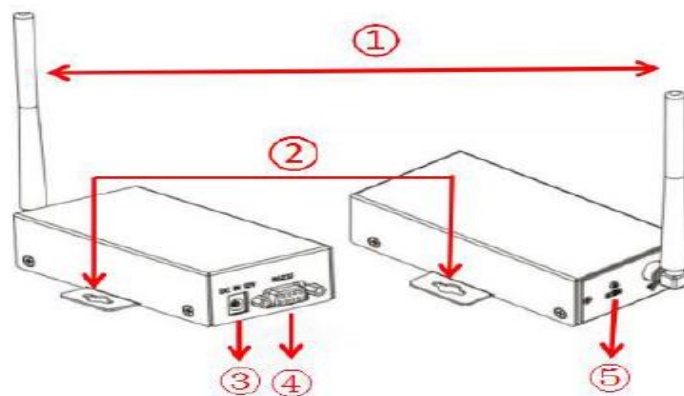

Number	Function
①	Antenna
②	Installation location
③	12Vac Input
④	RS232 Port
⑤	System Status LED

T3-18 WIFI module



② in Figure 3-18 is the mounting screw port, fixed on the bottom of ESS ③ connect port ⑬ in T2-6, ④ connect port ⑭ in T2-7

Operation Instructions

This chapter introduces the general operation instructions of integrated ESS, including power on/off.

Boot up the battery system

- Follow these steps to boot up the system.
- Step 1 Connect Wi-Fi module.
- Step 2 Connect to the Electricity Meter
- Step 3 Close the external AC output switch
- Step 4 Close the PV switch
- Step 5 Close MSD switch and battery switch.
- If the DC input voltage is higher than the start voltage, the ESS will start itself.
- Press ON-OFF button on the touch screen to boot up.

ESS Power off

- Power off the ESS, Please follow below steps.
- Step 1 Press ON/OFF button under touch screen to power off the system
- Step 2 open all switches which connect to inverter and battery switch.
- Step 3 open battery switch. The touch screen will be off in one minute.



US:
405 Boulder Court
Pleasanton, CA 94566
(925) 398-8466, (925) 954-4770
team@innoliaenergy.com



India:
16-11-741/c/3 Moosarambagh
Dilsukhnagar, Hyderabad 500060
040-40274296, +91-7799992037
+91-9010752755, info@innoliaenergy.com



Factory:
284-2-88/1 Lingotam
Kuntlagudem, Telangana 508252
+91-9182543576, +91-9825969807
+91-9866586771, sales@innoliaenergy.com

To Prolong the Lifespan of the System

This chapter introduces some common issue of ESS, Including safety precautions, preventive periodic maintenance, daily battery maintenance, fan maintenance, etc.

Maintenance guide

Correct maintenance is the key to the best operation of the equipment. Correct maintenance will ensure a long service life of the equipment.

Safety precautions

- Pay attention to the following safety operation procedures:
- Always be alert to the existence of dangerous voltage in the integrated system.
- Before maintenance, a multi-meter must be used to check whether there is dangerous voltage to ensure that the power supply is off and in a safe state.
- Before operating the ESS, remove rings, necklaces, watches and other conductive metal accessories.
- Operate in accordance with the safety operation procedures.
- If you have any questions, please consult the personnel familiar with the equipment.
- Keep the ESS free from dust or chemistry.



US:
405 Boulder Court
Pleasanton, CA 94566
(925) 398-8466, (925) 954-4770
team@innoliaenergy.com



India:
16-11-741/c/3 Moosarambagh
Dilsukhnagar, Hyderabad 500060
040-40274296, +91-7799992037
+91-9010752755, info@innoliaenergy.com



Factory:
284-2-88/1 Lingotam
Kuntlagudem, Telangana 508252
+91-9182543576, +91-9825969807
+91-9866586771, sales@innoliaenergy.com

Regular Inspection

- For fault-free, safe, reliable and long-lasting operation of the storage system, it is essential to carry out regular function checks and cleaning.
- Check the whether the input and output cable terminals are well contacted.
- Check the cooling fan. And make sure it is in good conditions.
- Check the battery voltage. And make sure the battery voltage is normal.
- Check the working status of the system in case there is any fault occurs.

Cleaning and maintenance

Safety precautions for battery maintenance

- Use only moist cloths, not wet cloths, to clean the system.
- Do not dip any oil or organic solvents for cleaning.
- Do not place the product nearby flammables.
- Do not short circuit the terminals.
- Do not damage the unit in such ways as dropping, deforming, impacting, cutting or penetrating with a sharp object.
- It may cause a leakage of electrolyte or fire.

Maintenance



US:
405 Boulder Court
Pleasanton, CA 94566
(925) 398-8466, (925) 954-4770
team@innoliaenergy.com



India:
16-11-741/c/3 Moosarambagh
Dilsukhnagar, Hyderabad 500060
040-40274296, +91-7799992037
+91-9010752755, info@innoliaenergy.com



Factory:
284-2-88/1 Lingotam
Kuntlagudem, Telangana 508252
+91-9182543576, +91-9825969807
+91-9866586771, sales@innoliaenergy.com



- At room temperature, the battery shall be charged and discharged once every 4-6 months, and the charging time shall not be less than 4H.
- At high temperature areas, the battery shall be charged and discharged once every two months, and the charging time shall not be less than 4H.
- Under the condition that the battery has not been discharged for a long time, it is required to charge the battery regularly every three months to activate the battery, and the charging time shall not be less than 4H.
- To avoid battery over-discharged, please charge the battery in time (no more than 24 hours) after discharged.
- Check whether the terminals are properly contacted every 6 months.
- If PV module is out of service, it is necessary to disconnect the battery to avoid long-term battery discharge of battery.

Battery module replacement

- Please consult professional engineer for battery replacement.
- Attention shall be paid to keep the battery consistence.
- Make sure they are the same capacity, type and from the same manufacturer, otherwise, it will affect the battery life cycle.
- The voltage difference of parallel battery should be within 3V.

Cleaning





The **I-DC48V** integrated ESS is recommended to be cleaned periodically. If the enclosure is dirty, please use a soft, dry cloth or brush to remove the dust. Liquids such as solvents, abrasives or corrosive liquids are not allowed to clean the enclosure.

Maintenance

- If the ESS needs to be disassembled for maintenance, please contact manufacturer for professional operation.
- Make sure the grid AC input, AC load, DC input and battery input are all safely disconnected from the inverter before maintenance.
- And wait for at least 5 minutes to ensure the battery system is fully discharged.

Troubleshooting

This chapter mainly introduces the fault handling of integrated ESS.

Fault List

Integrated ESS is designed in accordance with the standards and meets the relevant safety requirements. Before it is provided to users, the integrated ESS is tested strictly to ensure that it can run optimally and reliably for a long time.

Check the fault list table. You can locate the system fault type easily and quickly from information displayed on the screen.





T 6-1 Fault List

Items		Protection	Recoverable	Warning	Actions
PV input protection	PV input over voltage protection	Yes	Yes	Yes	Please inform the maintenance personnel
	Input (PV panel) connected with reverse protection	Yes	Yes	—	Please inform the maintenance personnel

PV input protection	Insulation failure	Yes	Yes	Yes	Please inform the maintenance personnel
	DC input overload protection	Yes	Yes	Yes	Please inform the maintenance personnel
Grid-tied output protection	Abnormal grid frequency	Yes	Yes	Yes	Repeated , Please inform the maintenance personnel
	abnormal power grid amplitude	Yes	Yes	Yes	Repeated , Please inform the maintenance personnel





	DC component of inverter current is abnormal	Yes	Yes	Yes	Please inform the maintenance personnel
	Inverter over current	Yes	Yes	Yes	Please inform the maintenance personnel
Grid-tied output protection	Short circuit protection	Yes	Yes	Yes	Please inform the maintenance personnel
	Electricity meter abnormal connection	Yes	Yes	Yes	Please inform the maintenance personnel
	Current leakage protection	Yes	Yes	Yes	Please inform the maintenance personnel
	Overload warning	No	Yes	Yes	Disconnect some mine loads

Off-grid output protection	Overload protection	Yes	Yes	Yes	Disconnect some mine loads , failure still , Please inform the maintenance personnel
----------------------------	---------------------	-----	-----	-----	--





	Short-circuit protection	Yes	Yes	Yes	Check whether there is short circuit outside. If there is no abnormality, please inform the operation and maintenance personnel
	DC component of inverter voltage is abnormal	Yes	Yes	Yes	Inform operation and maintenance personnel
Temperature protection	Heat sink overheating	Yes	Yes	Yes	inform operation and maintenance personnel
	overheating	Yes	Yes	Yes	inform operation and maintenance personnel
Other	Communication failure	No	Yes	Yes	inform operation and maintenance personnel
	Inside failures	Yes	Yes	Yes	inform operation and maintenance personnel

Packaging & Transportation & Storage

This chapter introduces the package, transportation and storage of integrated ESS.

Package



US:
405 Boulder Court
Pleasanton, CA 94566
(925) 398-8466, (925) 954-4770
team@innoliaenergy.com



India:
16-11-741/c/3 Moosarambagh
Dilsukhnagar, Hyderabad 500060
040-40274296, +91-7799992037
+91-9010752755, info@innoliaenergy.com



Factory:
284-2-88/1 Lingotam
Kuntlagudem, Telangana 508252
+91-9182543576, +91-9825969807
+91-9866586771, sales@innoliaenergy.com



- The integrated ESS is packed in carton boxes.
- The dimension of outer wooden package is 1170 (W) × 837 (d) × 460 (H).
- Attention shall be paid to the requirements for the placement, direction of each part during packing.
- The wooden box is marked with shipping mark and information about the
Products and manufacturers.

Transportation

- During transportation, the package shall be placed in the direction marked on the packing box.
- Do not crush, drop or puncture the battery.
- Do not ship the system with flammables.
- It may lead to fire or explosion.
- Store the system in a cool and dry place during transition.
- Do not make the system contact with water.

Storage

- The equipment shall be placed in the direction indicated on the packing box.
- The packing box shall be placed 20cm away from the ground and at least 50cm away from the wall, heat source, cold source, and window or air inlet.





INNOLIA ENERGY

INTEGRATED SOLAR, LITHIUM-BATTERY & EV COMPANY

Residential Storage

- The storage temperature is - 40 ~ 70 °C (the recommended storage temperature is - 20 ~ 40 °C). And the humidity is 20%~ 80%.
- No hazardous gas, inflammable, explosive and corrosive chemicals are allowed in the warehouse.
- The warehouse should be withstanding high frequency mechanical and magnetic field vibrations.
- After every 6 month of storage, the system needs to be rechecked again before installation.



US:
405 Boulder Court
Pleasanton, CA 94566
(925) 398-8466, (925) 954-4770
team@innoliaenergy.com



India:
16-11-741/c/3 Moosarambagh
Dilsukhnagar, Hyderabad 500060
040-40274296, +91-7799992037
+91-9010752755, info@innoliaenergy.com



Factory:
284-2-88/1 Lingotam
Kuntlagudem, Telangana 508252
+91-9182543576, +91-9825969807
+91-9866586771, sales@innoliaenergy.com